



CDVI

EN ENGLISH

FR FRANCAIS



BS60 BS60H

Uninterruptible PSU + Digital Clock Timer option (BS60H)
Alimentation secourue + Option horloge (BS60H)

The installer's choice
cdvigroup.com

BS60 - BS60H

Uninterruptible PSU + Digital Clock Timer Option (BS60H)

PRODUCT PRESENTATION

- **Regulated PSU.**
- **7 A/H battery included.**
- **Polycarbonate casing.**
- **Primary and secondary inputs protected by fuses.**
- **VO: fire-retardant.**
- **Additional AC output.**
- **Digital clock timer option: BS60H version.**

- Input voltage: 230V ± 10%, 50/60 Hz.
- Power consumption: 0.2A.
- Outputs:
 - 12V dc regulated, uninterruptible,
 - 12V ac non-interruptible.
- Maximum load current:
 - 12V dc output / 1.5A,
 - 12V ac output / 0.5A.

TERMINAL BLOCK OUTPUTS	VOLTAGE
C	Digital Clock Timer (BS60H only)
R	
T	
+	+12V dc
-	0V
~	12V ac
~	12V ac
1	230V ac
3	230V ac
4 (Black wire)	- Battery
5 (Red wire)	+ Battery

Assembly and Connections:

Remove the cover by unscrewing the 4 screws at the corners. Thread the wires through the holes designed for this purpose on the lower side. When mounting the casing on a wall, use the screw holes at the corners of the lower part of the casing. **When reassembling do not forget to reconnect the battery wires!**

COMPLIANT WITH EUROPEAN STANDARDS

EN 55022	EN 61000-4-2	EN 61000-4-5
EN 61000-3-2	EN 61000-4-3	EN 61000-4-6
EN 61000-3-3	EN 61000-4-4	EN 61000-4-11

This product must be installed in accordance with the local safety standards.

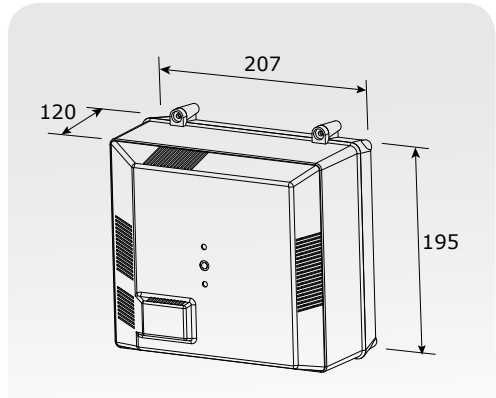

WEEE & RoHS



CE certification



IP30



0°C to +40°C

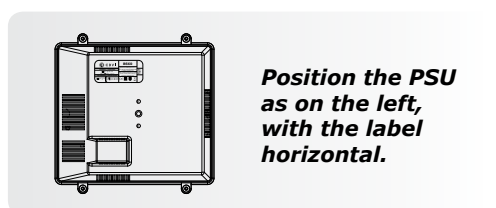
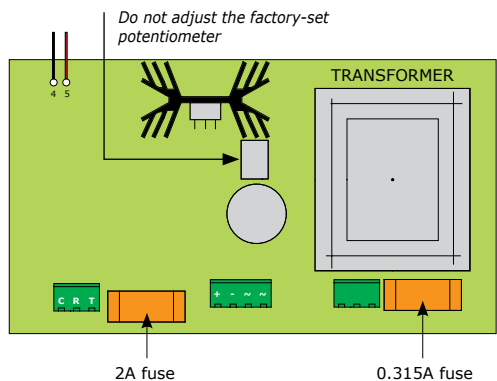

BS60 - BS60H

Alimentation secourue + Option horloge (BS60H)

PRESENTATION DU PRODUIT

- **Alimentation régulée.**
- **Batterie 7 A/h incluse.**
- **Boîtier polycarbonate.**
- **Protégée au primaire et au secondaire par fusibles.**
- **VO : ignifugé.**
- **Sorties supplémentaires AC.**
- **Option horloge: version BS60H.**
- Tension d'entrée : 230 V ± 10 %, 50/60 Hz.
- Consommation : 0,2 A.
- Sorties :
 - 12 V DC régulée, secourue.
 - 12 V AC non secourue.
- Intensité maximum :
 - sortie 12 V DC / 1,5 A.
 - sortie 12 V AC / 0,5 A.

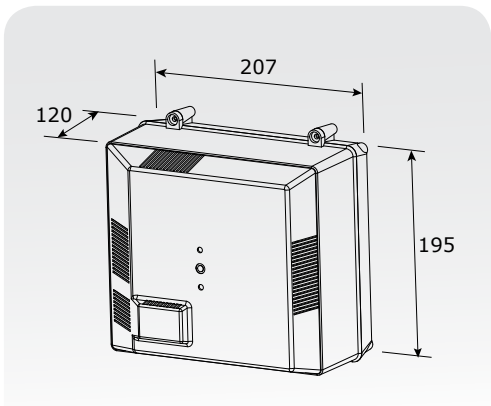

- DEEE & RoHS
- Certification CE
- IP30
- 0°C à +40°C

SORTIES BORNERS	TENSION
C	Horloge (BS60H uniquement)
R	
T	
+	+12 V DC
-	0V
~	12 V AC
~	12 V AC
1	230 V AC
3	230 V AC
4 (fil Noir)	- Batterie
5 (fil Rouge)	+ Batterie

Montage et Branchements:

Retirer le capot en dévissant les 4 vis situées aux coins. Faire passer les fils par les trous prévus à cet effet, situés sur le côté inférieur. Pour une fixation murale du boîtier, se servir des passages de vis situés au coins de la partie inférieure du boîtier. **Au remontage ne pas oublier de rebrancher les fils de la batterie !**

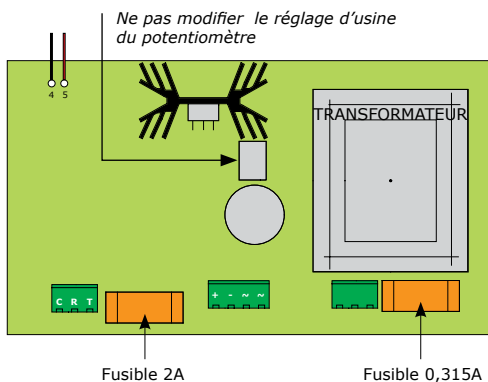

CONFORME AUX NORMES EUROPÉENNES

- | | | |
|--------------|--------------|---------------|
| EN 55022 | EN 61000-4-2 | EN 61000-4-5 |
| EN 61000-3-2 | EN 61000-4-3 | EN 61000-4-6 |
| EN 61000-3-3 | EN 61000-4-4 | EN 61000-4-11 |

Ce produit doit être installé selon les normes de sécurité électrique en vigueur dans votre pays



Reference : G0301FR0286V04

Extranet : EXE-CDVI_IM RETROFIT HOUSINGS-HANDLES CMYK A5 EN-FR 03



CDVI Group

FRANCE (Headquarter/Siège social)
Phone: +33 (0)1 48 91 01 02
Fax: +33 (0)1 48 91 21 21

CDVI

FRANCE + EXPORT
Phone: +33 (0)1 48 91 01 02
Fax: +33 (0)1 48 91 21 21

CDVI AMERICAS

[CANADA - USA]
Phone: +1 (450) 682 7945
Fax: +1 (450) 682 9590

CDVI

BENELUX
[BELGIUM - NETHERLAND - LUXEMBOURG]
Phone: +32 (0) 56 73 93 00
Fax: +32 (0) 56 73 93 05

CDVI

TAIWAN
Phone: +886 (0)42471 2188
Fax: +886 (0)42471 2131

CDVI

SUISSE
Phone: +41 (0)21 882 18 41
Fax: +41 (0)21 882 18 42

CDVI

CHINA
Phone: +86 (0)10 62414516
Fax: +86 (0)10 62414519

CDVI

IBÉRICA
[SPAIN - PORTUGAL]
Phone: +34 (0)935 390 966
Fax: +34 (0)935 390 970

CDVI

ITALIA
Phone: +39 0321 90 573
Fax: +39 335 127 89 96

CDVI

MAROC
Phone: +212 (0)5 22 48 09 40
Fax: +212 (0)5 22 48 34 69

CDVI

SWEDEN
[SWEDEN - DENMARK - NORWAY - FINLAND]
Phone: +46 (0)31 760 19 30
Fax: +46 (0)31 748 09 30

CDVI

UK
[UNITED KINGDOM - IRELAND]
Phone: +44 (0)1628 531300
Fax: +44 (0)1628 531003

CDVI DIGIT

FRANCE
Phone: +33 (0)1 41 71 06 85
Fax: +33 (0)1 41 71 06 86

All the information contained within this document (pictures, drawing, features, specifications and dimensions) could be perceptibly different and can be changed without prior notice.
Toutes les informations mentionnées à titre indicatif sur le présent document (photos, dessins, caractéristiques techniques et dimensions) peuvent varier et sont susceptibles de modifications sans notification préalable.

The installer's choice
cdvigroup.com